



RATMON

LEAK DETECTION

COMPREHENSIVE LEAK
DETECTION SYSTEM

SMART MONITORING · SMARTER CHOICES

www.ratmon.com

	NETWORK		SYSTEM		APPLICATION		PIPES		OPERATING MODE		PAGE
	district heating	cooling	impulse	resistance	detection	localisation	steel	plastic / PEX	stationary	portable	
RAT-2	x		x		x		x		x		2
RAT-2b	x			x	x	x	x		x		4
RAT-Combo	x	x	x		x	x	x	x	x		6
ILA-[®]	x	x	x		x	x	x	x	x		8
MEGALOC-[®]	x	x	x	x	x	x	x	x		x	10
SMARTLOC-[®]	x	x	x	x	x	x	x	x		x	12
SAM-1	x	x	x	x	x	x				x	14
SAM-2	x	x	x	x	x					x	15
PCS Pipe Control System											16
MSC-1 - MSC-2X	x	x	x		x	x	x	x			17
BLDS											18
Accessories											19

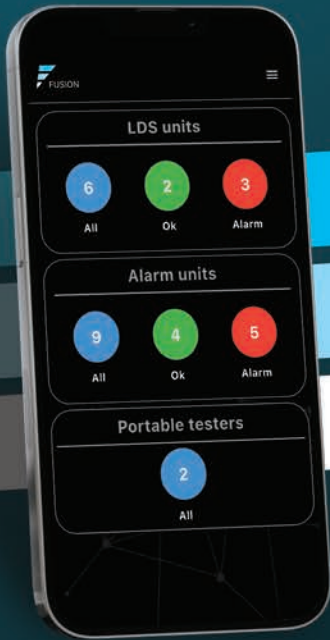

MEASUREMENTS AND VISUALISATION

DATA ANALYSIS

COMMUNICATION AND ALERTING



FUSION

REMOTE MONITORING
CRITICAL INFRASTRUCTURE MANAGEMENT

Key FUSION functionalities:

- Remote data acquisition from RATMON measurement devices
- Data and alarm management
- Resource sharing with other users
- Access via web interface and mobile application
- Generation of reports including measurement and location data
- Integration with other systems via API
- Alarm and alert system – immediate notification of alarm threshold exceedances
- Protect your investment and integrate with network operation systems
- Easy to deploy within existing client's infrastructure





RAT-2

Device for remote monitoring of pre-insulated Nordic district heating and cooling networks.

Fault detection is performed by measuring foam insulation resistance and alarm wire continuity.



General information:	Fault detection in impulsive and resistive networks	
Application:	District heating network	
Technical specification:	Measurement type	Specification
Main functions:	Insulation resistance	0.15 - 200 MΩ
	Loop resistance	0.15 - 100 kΩ
	Galvanic voltage	0 - 2,000 mV
	Continuous loop integrity monitoring	Detector triggering upon loop interruption
	Monitoring of connection to the steel pipe	Measurement of resistance between supply and return pipe
Insulation resistance measurement:	Measurement range	0.15 - 200 MΩ
	Test voltage	24 V
	Measurement current max.	max. 100 mA
	Measurement accuracy up to 1 MΩ	+/- (2% of reading + 8 digits)
	Measurement accuracy above 1 MΩ	+/- (5% of reading + 8 digits)
	<i>Measurement performed in two polarities</i>	
Loop resistance measurement:	Measurement range	0.15 - 100 kΩ
	Test voltage	24 V
	Measurement current max.	max. 100 mA
	Measurement accuracy	+/- (2% of reading + 8 digits)
	<i>Measurement performed in two polarities</i>	

Galvanic voltage measurement:	Measurement range Measurement accuracy	0 - 2,000 mV +/- 5%
External communication:	IoT / LoRaWAN / LAN / MODBUS / RELAY / GSM	
Number of channels:	2 or 4	
Measurement section length:	- maximum measurement distance up to 10 km - recommended measurement section length up to 1,500 m of wire	
Temperature range:	from -20 to +60 °C	
Power supply:	12 V DC / 120 - 240 V AC	
Enclosure:	IP65	
Dimensions:	200 x 150 x 75 mm	
Weight:	0.8 kg	

Software:

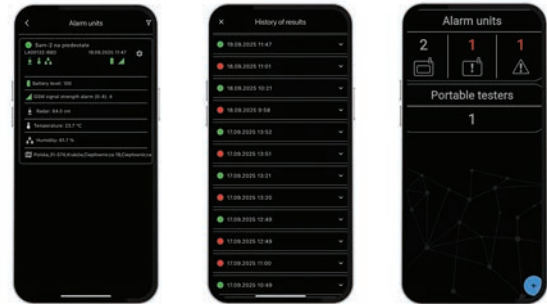
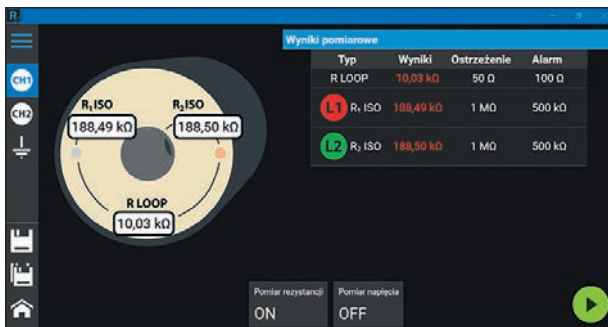

RAT MANAGER 2 - PC software for device, system configuration and management.



FUSION SYSTEM - web and mobile application for monitoring system and device status.

Package includes:

RAT-2 device with DIN mounting and cables
12 V AC/DC power supply
GSM/IoT antenna for devices with wireless communication module

Optional accessories:

DESCRIPTION	PART NUMBER
Battery module with R20 batteries	BAT-1
Additional external antenna with 3 m cable	ANT-1
Universal junction box - 2 measurement loops	BOX-1
Junction box - 1 measurement loop	BOX-3
Junction box with BNC/UHF connectors	BOX-5
Sealed power supply	ZH-1
Ground connector	GND-1
Sealed enclosure	SK-1 · SK-2 · SK-3

RAT-2b

Device for remote monitoring of pre-insulated Brandes district heating and cooling networks.

Dedicated to fault detection and location in resistive alarm systems.



General information:	Fault detection and location in resistive systems	
Application:	District heating network	
Technical specification:	Measurement type	Specification
Main functions:	Insulation resistance	0.15 - 200 MΩ
	Loop resistance	0.15 - 100 kΩ
	Galvanic voltage	0 - 2,000 mV
	Continuous loop integrity monitoring	Detector triggering upon loop interruption
	Monitoring of connection to the steel pipe	Measurement of resistance between supply and return pipe
Insulation resistance measurement:	Measurement range	0 - 200 MΩ
	Test voltage	24 V
	Measurement current max.	max. 100 mA
	Measurement accuracy up to 1 MΩ	+/- (2% of reading + 8 digits)
	Measurement accuracy above 1 MΩ	+/- (5% of reading + 8 digits)
	<i>Measurement performed in two polarities</i>	
Loop resistance measurement:	Measurement range	0.15 - 100 kΩ
	Test voltage	24 V
	Measurement current max.	max. 100 mA
	Measurement accuracy	+/- (2% of reading + 8 digits)
	<i>Measurement performed in two polarities</i>	

Galvanic voltage measurement:	Measurement range Measurement accuracy	0 - 2,000 mV +/- 5%
Localization module: <i>leak detection in resistive networks</i>	Measurement accuracy Localization threshold <i>Results presented in the FUSION system Results presented as a percentage of length, or converted into distance</i>	+/- 2 m +/- 0.2% section length < 2 MΩ
External communication:	IoT / LoRaWAN / LAN / MODBUS / RELAY / GSM	
Number of channels:	2 or 4	
Measurement section length:	- maximum measurement section length up to 10 km - recommended measurement section length up to 1500 m of wire	
Temperature range:	from -20 to +60 °C	
Power supply:	12 V DC / 120 - 240 V AC	
Enclosure:	IP65	
Dimensions:	150 x 200 x 70 mm	
Weight:	0.8 kg	

Software:

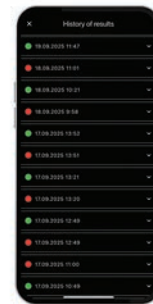
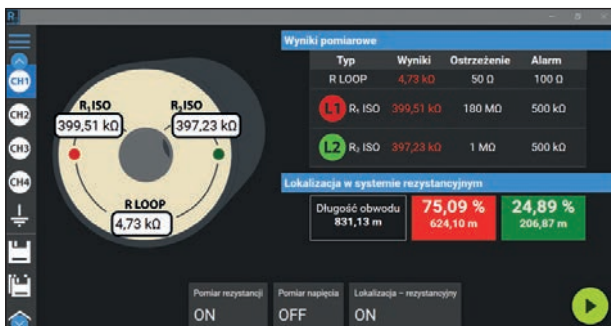

RAT MANAGER 2 - PC software for device, system configuration and management.



FUSION SYSTEM - web and mobile application for monitoring system and device status.

Package includes:

RAT-2b device with DIN mounting and cables

12 V AC/DC power supply

GSM/IoT antenna for devices with wireless communication module

Optional accessories:

DESCRIPTION	PART NUMBER
Battery module with R20 batteries	BAT-1
Additional external antenna with 3 m cable	ANT-1
Universal junction box – 2 measurement loops	BOX-1
Junction box with BNC/UHF connectors	BOX-5
Sealed power supply	ZH-1
Ground connector	GND-1
Sealed enclosure	SK-1 · SK-2 · SK-3



RAT-Combo

Diagnostic device for fault detection and location in impulse networks.

Detection is based on resistance measurement, and localisation using TDR (Time-Domain Reflectometry) technology.



General information:	Fault detection and location in impulse networks	
Application:	District heating and cooling networks	
Technical specification:	Measurement type	Specification
Main functions:	Insulation resistance	0.15 - 200 MΩ
	Loop resistance	0.15 - 100 kΩ
	Galvanic voltage	0 - 2,000 mV
	Continuous loop integrity monitoring	Detector triggering upon loop interruption
	Monitoring of connection to the steel pipe	Measurement of resistance between supply and return pipe
Insulation resistance measurement:	Measurement range	0.15 - 200 MΩ
	Test voltage	24 V
	Measurement current max.	max. 100 mA
	Measurement accuracy up to 1 MΩ	+/- (2% of reading + 8 digits)
	Measurement accuracy above 1 MΩ	+/- (5% of reading + 8 digits)
	<i>Measurement performed in two polarities</i>	
Loop resistance measurement:	Measurement range	0.15 - 100 kΩ
	Test voltage	24 V
	Measurement current max.	max. 100 mA
	Measurement accuracy	+/- (2% of reading + 8 digits)
	<i>Measurement performed in two polarities</i>	

Galvanic voltage measurement:	Measurement range Measurement accuracy	0 - 2,000 mV +/- 5%
Reflectometry module:	Measurement type Measurement range Pulse width Gain adjustment Pulse propagation velocity (VoP) Selectable measurement range segment Measurement accuracy Noise filtering	Specification up to 10 km (at VoP 100%) 1 - 70 ns x 30 40 - 100% 0 - 10 km +/- 0.01% of range +/- 1 px 50/60 Hz; 20 MHz, 100 MHz, 200 MHz, 350 MHz, 650 MHz, 750 MHz, 900 MHz
External communication:	GSM / LAN / RELAY	
Number of channels:	2 looped sections 4 non-looped sections	
Measurement section length:	- maximum measurement length up to 10 km - recommended measurement length up to 2 km	
Temperature range:	from -20 to +60 °C	
Power supply:	12 V DC / 120 - 240 V AC	
Enclosure:	IP65	
Dimensions:	200 x 150 x 75 mm	
Weight:	0.8 kg	

Software:

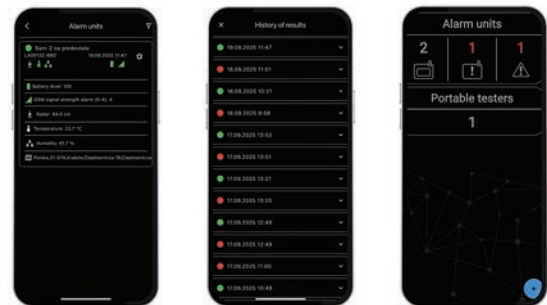
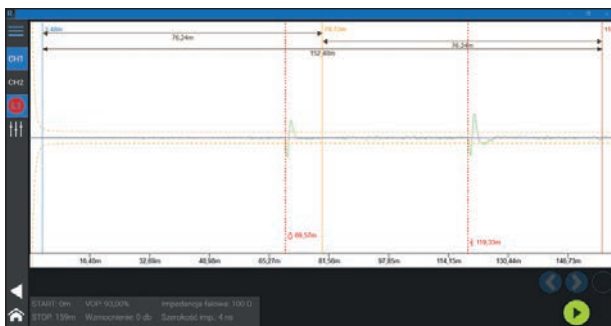

RAT MANAGER 2 - PC software for device, system configuration and management.



FUSION SYSTEM - web and mobile application for monitoring system and device status.

Package includes:

RAT-Combo device with mounting + 2 m BNC connection cables

12 V AC/DC power supply

Optional accessories:

DESCRIPTION	PART NUMBER
GSM modem for wireless communication	CEN-1
RAT-Combo junction box – 1 measurement loop	BOX-3
Junction box for sensing cable	BOX-9
Sealed enclosure	SK-1 · SK-2 · SK-3



ILA-2

Device designed for monitoring, detection and localisation of faults in pre-insulated networks.

Fault detection and localisation based on TDR technology.

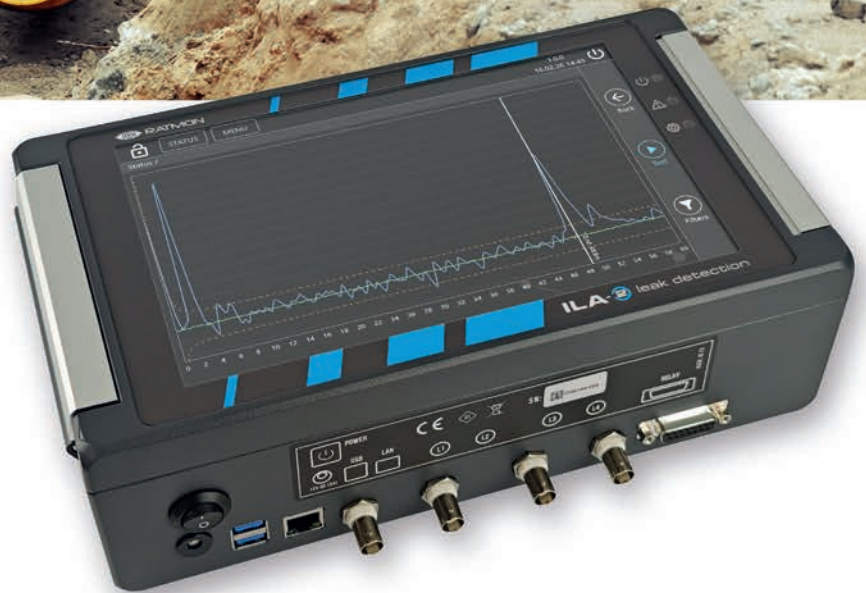

General information:	Fault detection and localisation in pre-insulated pipes
Application:	District heating and cooling networks
Technical specification:	
Channels:	2 looped sections 4 non-looped sections
Accuracy:	+/- 1 m
Display:	10" touch LCD
Alarm signaling:	Visualisation on screen, LED, RELAY
Detects multiple leak events:	YES
Cable type and application:	Leak detection and localisation using sensing cables in steel and plastic pipes
Leak identification:	Detection and localisation of faults (leak / break / short circuit)
BMS/SCADA compatible:	YES
Memory (fault and alarm history):	YES
External communication:	LAN / MODBUS / GSM / RELAY / BMS / SCADA Communication with external systems via MODBUS TCP/IP Detector positioning and status on map Communication with FUSION system

Power supply:	12 V DC / 120 - 240 V AC
Temperature range:	from -20 to +70 °C
Maximum measurement range:	4 km of alarm loop
Enclosure:	IP54
Dimensions:	300 x 170 x 90 mm
Weight:	3.2 kg

Software:



FUSION SYSTEM - web and mobile application for monitoring system and device status.

Package includes:

- ILA-2 device
- Power supply

Optional accessories:

DESCRIPTION	PART NUMBER
GSM modem for wireless communication	CEN-1
Junction box for pipes with sensing cable MSC-1 for 2 measurement loops	BOX-9
Sealed enclosure adapted for ILA-2 device	SK-1 · SK-2 · SK-3



MEGALOC-2

Portable diagnostic device for fault detection and location, designed for operation in harsh conditions.

Supports all types of alarm systems including impulse and resistance based systems. Ideal for service teams conducting field inspection or repair.



General information:

- Fault location in impulse networks using a reflectometer
- Fault location in resistive systems
- Insulation resistance measurement
- Loop continuity measurement
- 10" touch screen
- Water- and shock-resistant case
- Battery-powered and possibility of power bank supply
- Data storage on USB drive or in the FUSION system
- Protection class IP65

Technical specification:

Fault location using reflectometer:

Measurement range	up to 10 km (at VoP 100%)
Pulse width	1 - 70 ns
Gain adjustment	x 30
Pulse propagation velocity (VoP)	40 - 100%
Selectable measurement range segment	0 - 10 km
Measurement accuracy	+/- 0.01% of range +/- 1 px
Noise filtering	50/60 Hz; 20 MHz, 100 MHz, 200 MHz, 350 MHz, 650 MHz, 750 MHz, 900 MHz

Leak localisation module for resistive networks: <i>(option - MEGALOC-2B)</i>	Measurement accuracy Localisation threshold <i>Localisation results presented in percentage and meters</i>	+/- 1 m +/- 0.2% of section length < 2 MΩ
Insulation resistance measurement:	Measurement range Test voltage Measurement current Measurement accuracy up to 1 MΩ Measurement accuracy above 1 MΩ <i>Measurement performed in two polarities</i>	0.15 - 200 MΩ 24 V max. 100 mA +/- (2% of reading + 8 digits) +/- (5% of reading + 8 digits)
Loop resistance measurement:	Measurement range Test voltage Measurement current max. Measurement accuracy <i>Measurement performed in two polarities</i>	0.15 - 100 kΩ 24 V max. 100 mA +/- (2% of reading + 8 digits)
Galvanic voltage measurement:	Measurement range Measurement accuracy	0 - 2000 mV +/- 5%
Dimensions:	290 x 280 x 140 mm	
Weight:	3.2 kg	

Software:

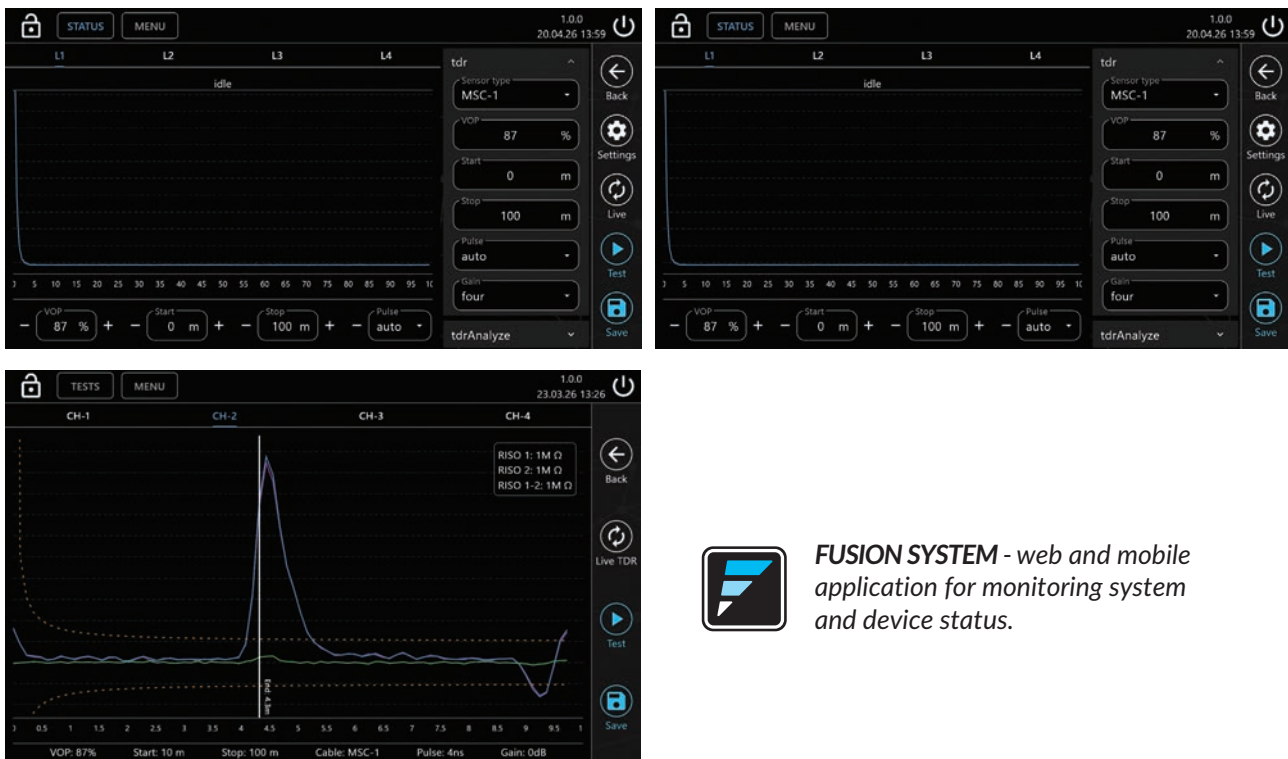

FUSION SYSTEM - web and mobile application for monitoring system and device status.

Package includes:

- MEGALOC-2 device
- Magnetic ground connector
- Charger
- Cable set 2 pcs.
- USB flash drive
- Alligator clips 4 pcs. standard + alligator clips 4 pcs. mini
- Carrying case



SMARTLOC-2

Dedicated diagnostic device for inspection of alarm systems in all types of pre-insulated networks, including impulse and resistive systems.

Designed for operation in harsh conditions.
Suitable for use during network construction, as well as operation.
Works with the Fusion mobile application, enabling reading of results with GPS location and report generation.



General information:

- Alarm loop continuity measurement
- Determination of alarm loop length
- Foam insulation resistance measurement
- Moisture level expressed in Q and MH degrees
- Leak detection in resistive networks
- Battery-powered
- Clear display
- Intuitive operation using large keypad buttons
- Automatic measurement evaluation
- Ergonomic enclosure
- Wireless communication with Fusion application
- Protection class IP65
- GPS coordinates logging
- Report for each measurement point (joint)
- Ability to add photos and notes via paired Fusion app
- Monitoring of measurement cable connection to the pipe

Technical specification:

Insulation resistance measurement:

Test voltage	24 V, optionally 250 V and 500 V
Measurement range	(24V) 20 Ω-100 MΩ, (250, 500V) 20 Ω - 250 MΩ
Measurement current	max. 10 mA (2 mA at 500 V)
Measurement accuracy	+/- (2% of reading + 4 digits)

Loop resistance measurement:	Measurement range Measurement range Measurement voltage Measurement current <i>Measurement performed in two polarities</i>	0.15 Ω - 2 kΩ Cu 0.15 Ω - 50 kΩ NiCr max. 24 V max. 10 mA
Galvanic voltage measurement:	Measurement range Measurement accuracy	0 - 2,000 mV +/- 5%
Temperature range:	from -20 to +50 °C (storage temperature from 5 to 30 °C)	
Dimensions:	200 x 100 x 60 mm	
Weight:	0.6 kg	

Software:

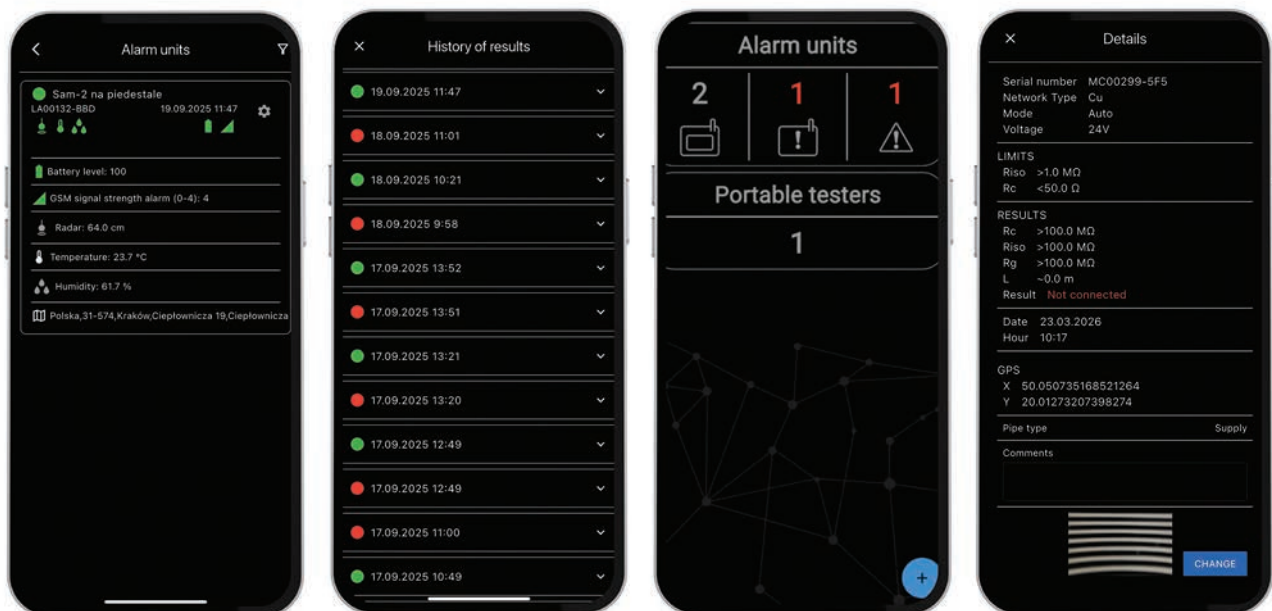

FUSION SYSTEM - web and mobile application for monitoring system and device status.

Package includes:

- SMARTLOC-2 device
- Magnetic ground connector
- Battery set
- Cable set 4 pcs.
- Alligator clips – 4 pcs. standard + 4 pcs. mini
- Carrying bag

SAM-1

Designed for remote monitoring of facilities such as tanks, manholes, chambers, and other environments exposed to harsh conditions.



General information:

The device links to various sensors, e.g. flooding, opening, temperature, pressure, humidity. SAM-1 can be used to supplement leak detection data in heat networks for a more accurate picture of events. Collected alarm data is transmitted wirelessly (IoT) to the FUSION system or another external monitoring system.

Specification:

- Up to 5 independent inputs/sensors
- Up to 5 years of operation on battery power
- Measured temperature range: -55°C to +125°C
- Measured humidity range: 0 - 100% RH
- IoT communication using MQTT protocol
- Compatibility with FUSION system
- Operating temperature range: -20 to +80 °C (storage from +5 to +25 °C)
- Protection class IP67
- Dimensions: 190 x 130 x 60 mm
- Weight: 0.25 kg

Sensors:

- Manhole opening sensor **S-1**
- Flood sensor **S-2**
- Temperature sensor **TEMP-1**

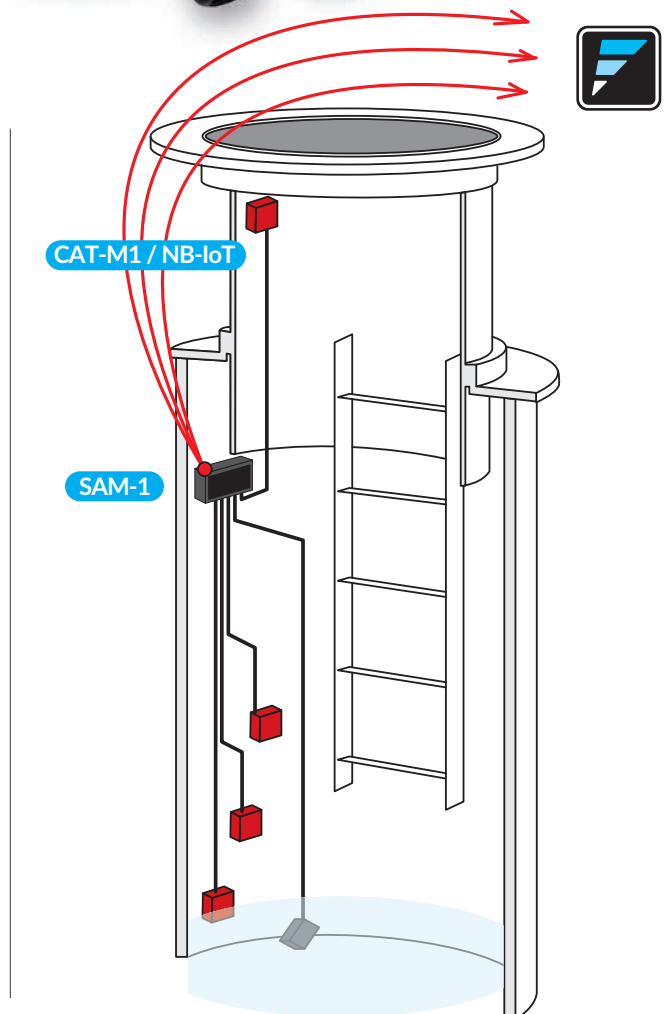

SAM-2

Autonomous radar-based liquid level detector for tanks
Built-in radar sensor enables non-contact monitoring of the environment.

General information:

Excellent solution for remote monitoring of hard-to-access locations. Equipped with its own power supply and modern IoT communication. Built-in radar sensor monitors liquid level changes and tank filling level.

Application:

- Water tanks
- Septic tanks
- River level monitoring
- Monitoring of flood-prone areas

Specification:

- Radar-based detection
- Battery operation up to 3 years
- Wireless IoT communication
- Measured temperature range from 0 to +90 °C (±2°)
- Compatibility with FUSION system
- Operating temperature from -20 to +80 °C (storage from +5 to +25 °C)
- Protection class IP67
- Dimensions: 190 x 130 x 80 mm
- Weight: 0.3 kg

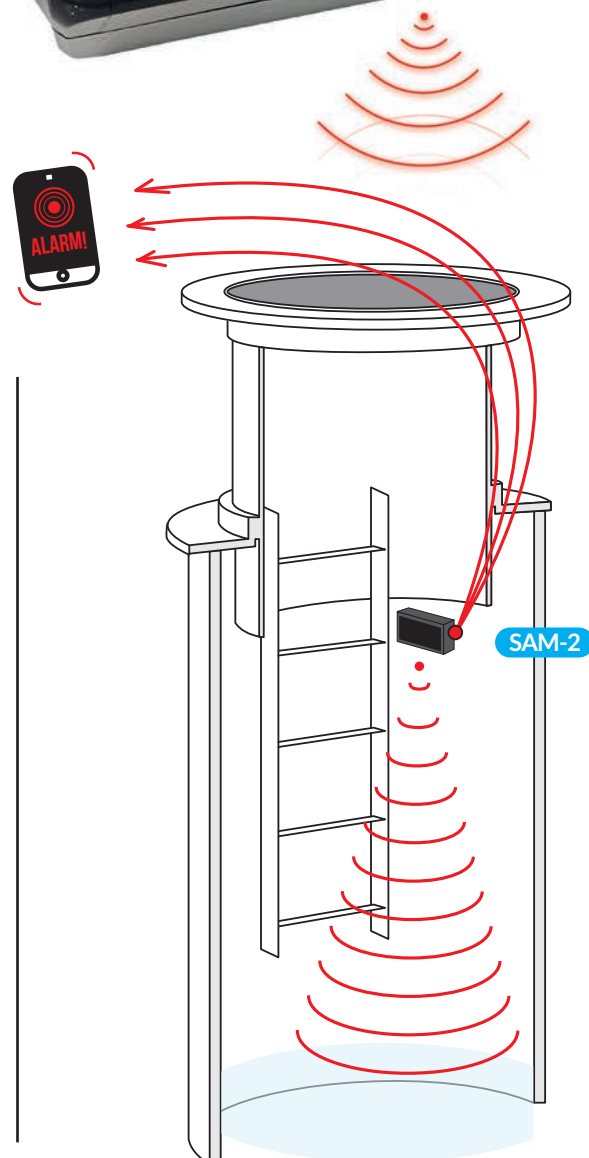



PCS

Pipe Control System



Production testing system for pre-insulated pipes.
 Inspection is performed within seconds by comparing the image of the tested object with a reference pattern.

Application:

Quality control of pre-insulated pipes and fittings using TDR technology.

Detects:

- incorrect positioning of the alarm wire,
- quality of polyurethane foam filling,
- wire break.

Specification:

Measurement range: 1 - 30 m
 Measurement time: 5 s
 Galvanic isolation
 Adjustable measurement thresholds

Package:

- computer and display
- power cable
- measurement cable – 2 standard alligator clips
- USB cable
- RAT-Combo device
- Mounting frame
- PCS software

reference waveform ○

analysis waveform ○

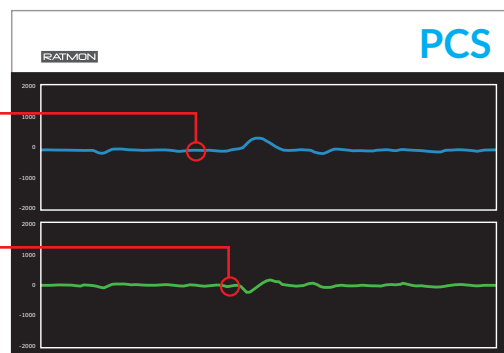

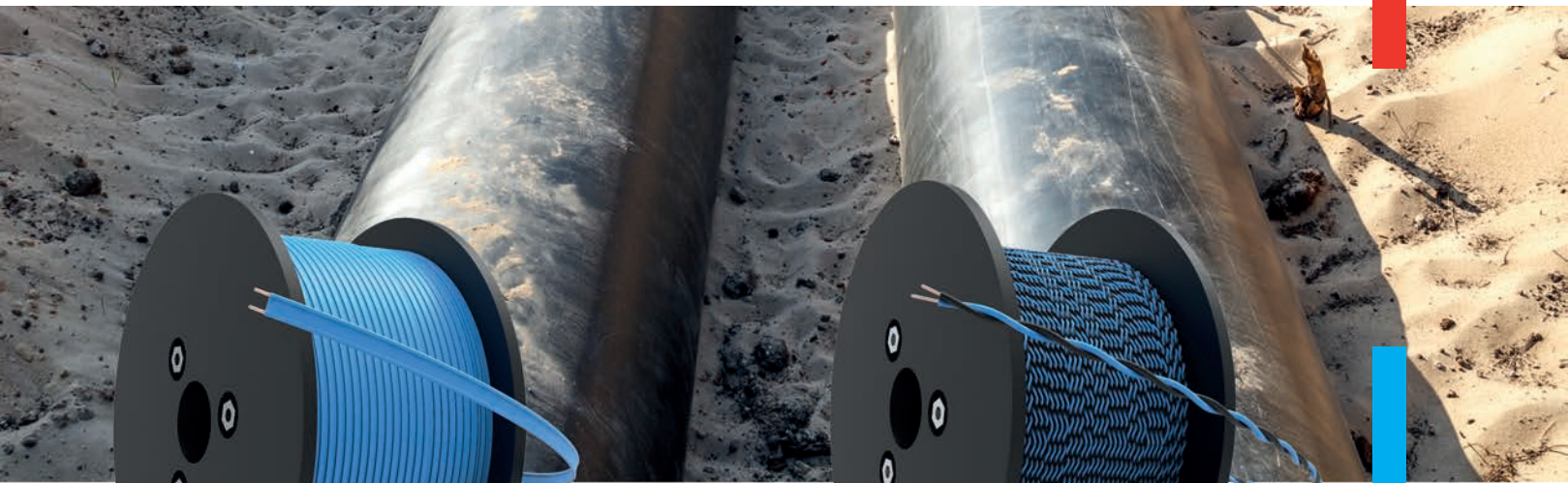

MSC-1

MSC-1 is our patented solution made with twin core cables to enable precise detection and localisation of faults in pre-insulated pipes used in district heating and cooling systems.

Fully insulated cables reduce the risk of false alarms caused by condensation. It is also an excellent solution for monitoring plastic pre-insulated pipes, especially straight sections where conventional alarm wires are not effective.

MSC-2X

MSC-2X is an advanced sensing cable made of two twisted conductors. It enables precise detection and localisation of faults in FLEX-type pipes.

Sensing cable for leak detection and localisation, consisting of two single insulated copper conductors, twisted in parallel and insulated with XLPE. Thanks to its modern design, MSC-2X increases the reliability of system monitoring, and the use of a SMART ADAPTER enables integration with traditional impulse systems.

General information:	Detection and fault localisation
Application:	District heating and cooling networks Straight pipes, steel or plastic, FLEX-type pipes
Detection / localisation method:	Reflectometer

Technical data:	MSC-1:	MSC-2X:
Cable insulation:	PVC	XLPE
Conductors:	flat twin-core cable	twisted pair
Dimensions:	width: 8.3 mm height: 2.2 mm spool length: 500 m	width: 8.3 mm height: 2.2 mm spool length: 500 m
Operating temperature:	from -40°C to +120°C	from -40°C to +125°C
Loop resistance:	30 Ω / 1 km of cable +/-5% at 20 °C	30 Ω / 1 km of cable +/-5% at 20 °C
VOP (velocity of propagation):	80% for polyurethane foam	68% for polyurethane foam



BLDS

Building Leak Detection System

General information:

The BLDS system is designed for leak detection and localisation in buildings, or other enclosed facilities where moisture and flooding may pose a risk to property or health. The system enables the creation of an extensive monitoring and leak detection network in multi-zone areas.

Specification:

- Immediate leak detection
 - response time below 2 seconds
- Precise fault location with accuracy up to 1 meter
- Fault identification for specific zones
- Easy system reset after flooding event
- Scalable sensor network architecture
- The system consists of a communication control unit to which sensing cables (MSC-7X) and splitters are connected
- Integration with systems: FUSION, RATMON, BMS, SCADA, GIS, etc.
- High environmental resistance
 - enclosure rated IP65

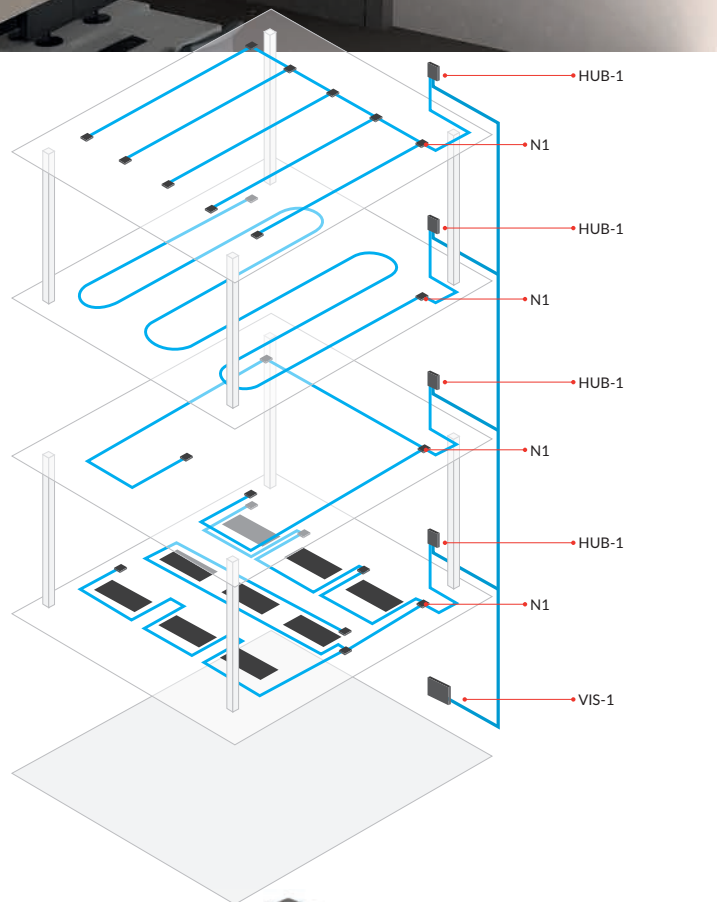

BOX-1**Dual-channel basic junction box**

- Application in impulse and resistive networks
- Supports two measurement channels (two alarm loops)
- Mechanical mounting using two mounting brackets
- Measurement wires connected via terminal blocks
- Measuring device connected via detachable terminal blocks, enabling quick disconnection from the monitored loop
- Maximum connection wire diameter 7 mm
- Enclosure IP65
- Dimensions: 150 x 70 x 60 mm
- Weight: 0.2 kg
- **Compatible with:** RAT-2 • RAT-2b

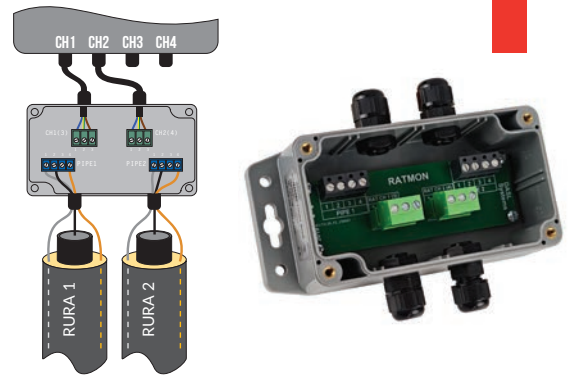
**BOX-3****Single-channel constant impedance junction box BNC/UHF**

- Application in impulse networks
- Supports one measurement channel (one alarm loop)
- Mechanical mounting on pre-insulated pipe
- RAT-Combo device connected directly via BNC cables
- Enclosure IP65
- Dimensions: 50 x 50 x 50 mm
- Weight: 0.15 kg
- **Ensures highest measurement accuracy**
- **Compatible with:** RAT-Combo • RAT-2 • ILA-2

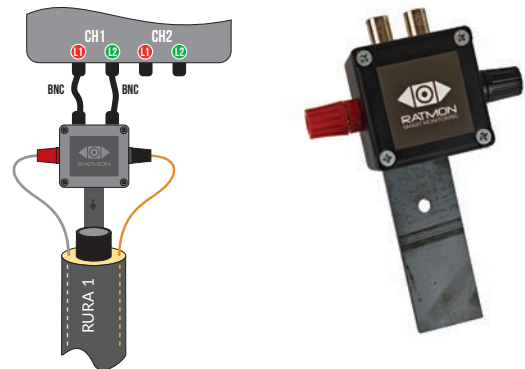
**BOX-5****Dual-channel junction box with BNC connector**

- Application in impulse networks
- For convenient connection of pre-insulated pipes with RAT-2 devices
- Supports two measurement channels (two alarm loops)
- Mechanical mounting using two mounting brackets
- Measuring device connected via detachable terminal blocks, enabling quick disconnection from the monitored loop
- Enclosure IP65
- Dimensions: 190 x 130 x 60 mm
- Weight: 0.3 kg
- **Compatible with:** RAT-2

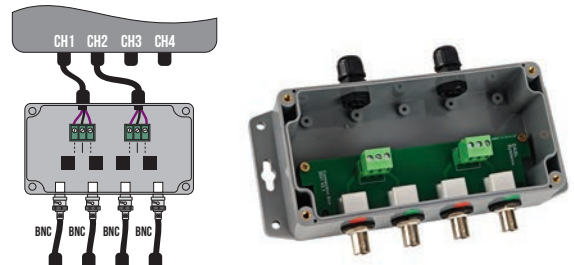
**BOX-9****Dual-channel junction box for MSC-1**

- Application – MSC-1 and MSC-2X sensing cables
- For permanent connection of RAT-Combo / ILA-2 with pre-insulated pipes equipped with MSC-1 sensing cable
- Supports up to 4 sensing cables
- Mechanical mounting using two mounting brackets
- Measurement wires connected via terminal blocks
- Measuring device connected via coaxial cables with BNC connectors
- Enclosure IP65
- Dimensions: 190 x 130 x 60 mm
- Weight: 0.36 kg
- **Compatible with:** RAT-Combo • ILA-2

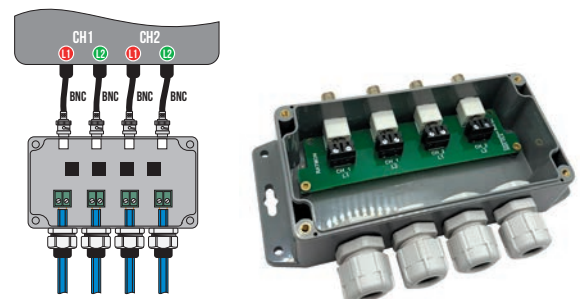

SOL-1

Solar power supply kit

Complete solar kit enabling installation of RAT series devices for monitoring pre-insulated networks in locations with limited access to power supply. The set is designed to ensure stable operation even during extended periods of cloudy weather.

The kit includes:

- Solar panel
- Charge controller
- Battery
- Sealed enclosure for battery and charge controller
- Dimensions: 251 x 186 x 107 mm
- Weight: 1.75 kg
- **Compatible with:** RAT-2 • RAT-2b • RAT-Combo



ANT-1

External antenna

- Additional external GSM antenna
- Type: RF
- Antenna gain: 3 dBi
- Linear polarization
- Impedance 50 Ω
- Frequency 470–862 MHz
- Mounting: magnetic base
- Cable 3 m, SMA connector
- Dimensions: height 15 cm, base diameter 3 cm
- Weight: 0.15 kg
- **Compatible with:** RAT-2 • RAT-2b • RAT-Combo • ILA-2



BAT-1

Battery module

- Output: 12 V DC
- 8 x R20 batteries (optional)
- Protection class: IP65
- DIN rail mounting
- Dimensions: 19 x 12 x 9 cm
- Cable length 30 cm
- Weight: 1.55 kg
- **Compatible with:** RAT-2 • RAT-2b



ZH-1

Sealed power supply

- Dimensions: 78 x 118 mm
- Height: 55 mm
- Input: 230 V
- Output: 12 V DC
- IP65
- Weight: 500 g
- DIN rail mounting
- Input cable 150 cm
- Output cable 150 cm
- **Compatible with:** RAT-2 • RAT-2b • RAT-Combo • ILA-2



MZM-1

Magnetic ground connector

- Secure and stable connection to the pipe
- Design ensures a high quality connection with the pipe
- Two independent 4 mm banana sockets
- Made of high-quality stainless steel
- Weight: 0.1 kg
- Dimensions: 50 x 50 x 16.5 mm
- **Compatible with:** SMARTLOC-2 • MEGALOC-2



GND-1 Pipe connection – grounding connector

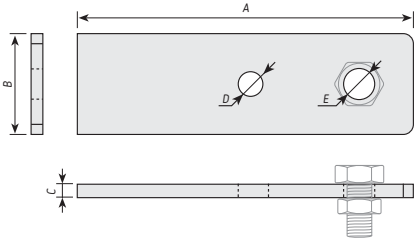

- Dimensions: (A) 100 x (B) 30 x (C) 4 mm, (D) – 6 mm, (E) 9 mm
- Weight: 0.08 kg
- **Compatible with:** steel pipes, pre-insulated pipes



SK-1 Sealed enclosure

- Material: polyester
- Lock with key
- NEMA certification
- Mounting plate
- Protection class
- Enclosure IP66 (NEMA 4X)
- Dimensions: 530 x 430 x 200 mm
- Weight: 5.5 kg
- **Compatible with:** RAT-2 • RAT-2b • RAT-Combo • ILA-2



SK-2 and SK-3 Sealed enclosure

- Material: SK-2 ABS – SK-3 ABS + polycarbonate cover
- Lock with key
- ROHS certification
- Mounting plate
- Protective conductor
- Protection class IP65
- Wall-mounted enclosure
- Dimensions: 410 x 610 x 202 mm
- Weight: SK-2 – 5.5235 kg, SK-3 – 5.7464 kg
- **Compatible with:** RAT-2 • RAT-2b • RAT-Combo • ILA-2



Example methods of connecting devices to pipes

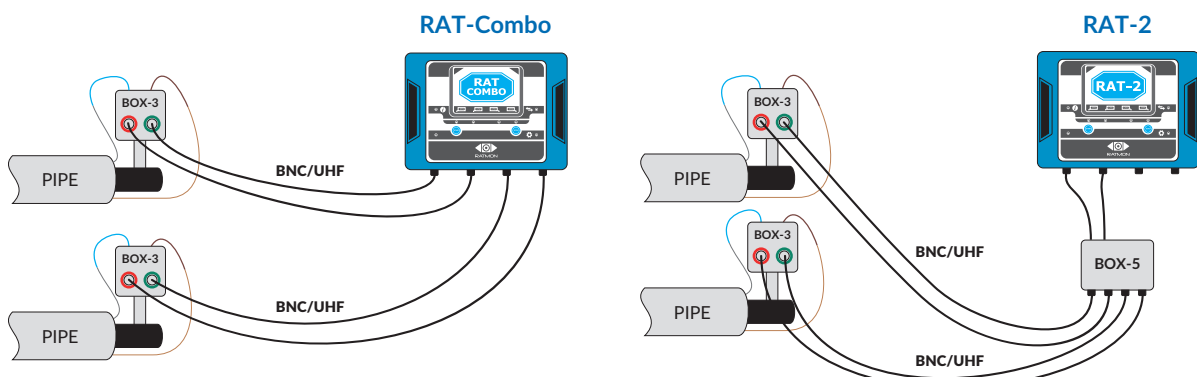



Ratmon Ltd.

ul. Ciepłownicza 19
31-574 Cracow, Poland
tel.: +48 12 296 50 68
tel.: +48 663 226 322
ratmon@ratmon.com

Ratmon - UK & Ireland

Station Road West,
Ash Vale, Hampshire,
Aldershot, GU12 5LZ
tel.: +44 1794 325 107
info@ratmon.co.uk
www.ratmon.co.uk

Ratmon North America

20505 SE I-55 Frontage Rd Joliet,
Illinois 60431, United States
Sales: sales@ratmonna.com
+1 779 279 4987
Service: service@ratmonna.com
+1 815 735 4660

Ratmon Middle East

SAIF Suite Z-09 Sharjah
tel.: +971 52 192 9848
r.mohan@ratmon.com

